



Electrolux

Modular Cooking Range Line 700XP Gas Solid Top with 4 Burners

ITEM # _____

MODEL # _____

NAME # _____

SIS # _____

AIA # _____



Electrolux

Modular Cooking Range Line
700XP Gas Solid Top with 4 Burners



Modular Cooking Range Line
700XP Gas Solid Top with 4 Burners

371012 (E7STGL5000)

Simple service - half module central gas solid top (3,8 kW) with 2 burners on the left and 2 burners on the right (5,5 kW each)

Short Form Specification

Item No. _____

High efficiency 3.8 kW central burner, flame failure device and protected pilot light. Suitable for natural gas or LPG. Large cooking surface with different heating zones. Large flat cooking surface made in cast iron allows for the use of a number of various sized pots and pans, all easily moved across the surface without lifting. Four high efficiency 5,5 kW flower flame burners with continuous power regulation and protected pilot light interchangeable on site. Flame failure device as standard on burners to protect against accidental extinguishing. Exterior panels in stainless steel with Scotch Brite finish. One piece pressed work top in 1.5 mm thick stainless steel. Right-angled side edges to allow flush-fitting junction between units.

Main Features

- Gas heated, 3.8 kW central burner, solid top.
- Durable cast iron cooking plate, easy to clean.
- The center of the plate can reach a maximum temperature of 500 °C while decreasing outwards.
- Central burner with optimized combustion, flame failure device and protected pilot light.
- Temperature gradients to satisfy different cooking needs, provided over the whole plate thanks to the temperature fine-tuning by zone.
- Various sizes of pans can be used at the same time due to large surface area with no intermediate sectors.
- Pans can easily be moved from one area to another without lifting.
- Burners with optimized combustion interchangeable on site.
- Flame failure device on each burner protects against gas leakage when accidental extinguishing of the flame occurs.
- All major compartments located in front of unit for ease of maintenance.
- IPX4 water resistance certification.

Construction

- All exterior panels in Stainless Steel with Scotch Brite finishing.
- One piece pressed 1.5 mm work top in Stainless steel.
- Model has right-angled side edges to allow flush fitting joints between units, eliminating gaps and possible dirt traps.

Optional Accessories

- 4 wheels, 2 swivelling with brake PNC (700/900XP). It is mandatory to 206135 install with base supports for feet/wheels.
- Support for bridge type system, PNC 1200mm 206139
- Support for bridge type system, PNC 1400mm 206140
- Support for bridge type system, PNC 1600mm 206141
- Frontal kicking strip, 1200mm (not for refr-freezer base) PNC 206178
- Single burner smooth plate for direct cooking - fits frontal burners only PNC 206260
- Single burner ribbed plate for direct cooking- fits frontal burners only PNC 206261

APPROVAL: _____



Electrolux

Modular Cooking Range Line 700XP Gas Solid Top with 4 Burners

- Water column with swivel arm (water column extension not included) PNC 206289
- Water column extension for 700 line PNC 206291
- Stainless steel double grid for 2 burners PNC 206297
- Right and left side handrails PNC 206307
- Wok pan support for open burners (700/900) PNC 206363
- Base support for feet or wheels - 800mm (700/900) PNC 206367
- Base support for feet or wheels - 1200mm (700/900) PNC 206368
- Rear paneling - 1200mm (700/900) PNC 206376
- Kit town gas nozzles (G150) for 700 solid top and burner PNC 206388
- Chimney grid net, 400mm PNC 206400
- Frontal handrail 1200mm PNC 216049
- Frontal handrail 1600mm PNC 216050
- Large handrail - portioning shelf, 800mm PNC 216186
- 2 side covering panels for top appliances PNC 216277
- Pressure regulator for gas units PNC 927225



Modular Cooking Range Line
700XP Gas Solid Top with 4 Burners

The company reserves the right to make modifications to the products without prior notice. All information correct at time of printing.

2016.07.13

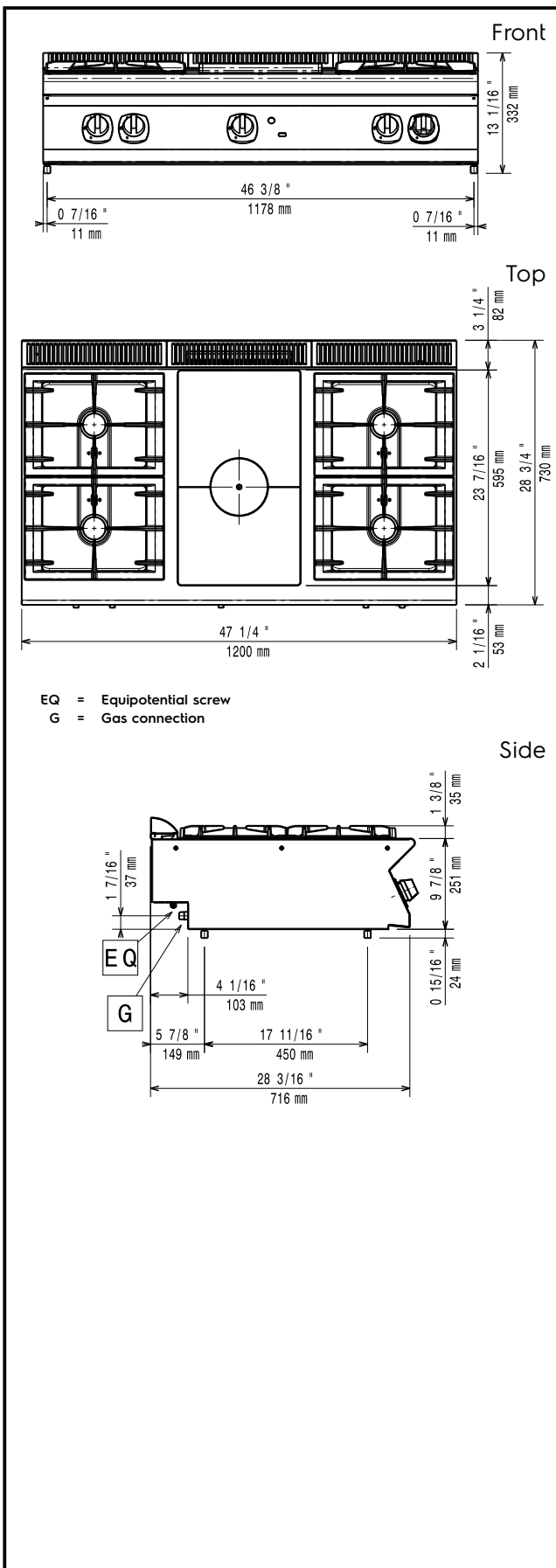

Gas

Gas Power:	
371012 (E7STGL5000)	87270.4 Btu/hr (25.6 kW)
Standard gas delivery:	Natural Gas
Gas Type Option:	;LPG
Gas Inlet:	1/2"

Key Information

Front Burners Power	5.5 - 5.5 kW
Back Burners Power	5.5 - 5.5 kW
Back Burners Dimension - mm	Ø 60 Ø 60
Front Burners Dimension - mm	Ø 60 Ø 60
Solid top usable surface (width):	340 mm
Solid top usable surface (depth):	595 mm
External dimensions, Height	250 mm
External dimensions, Width	1200 mm
External dimensions, Depth	730 mm
Net weight:	70 kg
Shipping weight:	90 kg
Shipping height:	540 mm
Shipping width:	830 mm
Shipping depth:	1300 mm
Shipping volume:	0.58 m ³

If appliance is set up or next to or against temperature sensitive furniture or similar, a safety gap of approximately 150 mm should be maintained or some form of heat insulation fitted.